



## **BERNSTEIN Aluminium Suspension Systems** **CS-3000 and CS-3000** *next*

Flexible, easy to assemble, ergonomic

# Flexibility in operation and monitoring: The BERNSTEIN CS-3000 Family

In the main, system constructors expect modern suspension systems to feature variable configuration, progressive design and complete ease of installation. BERNSTEIN sets standards with the CS-3000 family: Modern industrial design, well-conceived ergonomics and multiple component combinations to create an innovative system solution on a modular principle.



## Product features

- Long service life and safe operation thanks to anodised aluminium tubes
- Clean lines, thanks to smooth transitions between the tube and system components (very easy to clean)
- Coated tube fastening screws for sealing the thread holes and secure connections
- Relative appearance and connection of narrow profiles thanks to the possibility of reducing the cross section from square to round tube
- Protection class IP 65
- Modular flexible system lets you upgrade the couplings (also after installation), e.g. with adapters for slim enclosures or with tilt adapters
- Well designed ergonomics for simple and virtually fatigue free operation
- An ideal solution from a single source with BERNSTEIN control enclosures

## Assembly

Thanks to the particularly easy way the CS-3000 family components combine, assembly is quick and simple, which for the system builder means great time savings and cost reductions.



Smooth combination through an intelligent design for easy-cleaning



Additional connection security through component design at the mounting area



User friendly adjustment at any time – without disassembling the complete system

### In addition to the 'clamping' connection of the tube fastening screws:

- Sixfold positive connection is achieved via component design in the tube attachment area (optional additional safety screw for vertical mounting is not required)
- One person can install the complete system
- Stepless adjustment of system alignment by means of the tube fastening screws
- Readjustment possible at any time without disassembling the complete system
- Cable and assembly access covers on all deflection points in the system
- Different tube lengths offer the possibility of variability in assembly
- Tubes machined at one end so that users can cut to required length (machining templates supplied)

# The new BERNSTEIN Aluminium Suspension System CS-3000<sup>neXt</sup>

The CS-3000 neXt combines functionality with an appealing design. The new system is an important addition to the CS-3000 series, it is easy to clean and benefits from simplified installation, outstanding visual characteristics such as smooth transitions between tube and component and the high quality which BERNSTEIN is known for. The wide range of components, the high strength of the system and the load capacity provide individual solutions.



## Product features

- Light-duty suspension system for lightweight control enclosures up to 50 kg with an extension arm length of 1 m
- Modular system for rapid implementation of individual solutions
- Maximum system length: 1.5 m
- Compatible with the CS-3000 series
- Panel couplings



## Materials

- Anodised aluminium profiles
- Components: Aluminium die cast
- Aluminium covers on installation openings
- Bearings: POM
- Seals: Neoprene

## Colour

- Components: white aluminium, RAL 9006
- Tubes: Aluminium, naturally anodised
- Components and tubes can all be optionally powder-coated to a wide variety of RAL colours

## Load diagram for static load capacity CS-3000 *next*

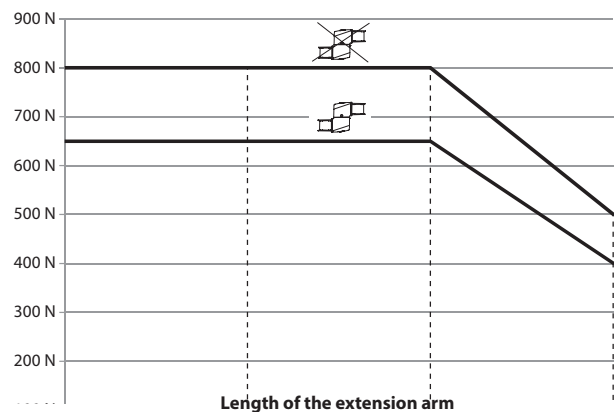

# Highlights



## Reducing elbow

- For combination of the CS-3000 with the light-duty suspension system CS-3000 neXt
- Fields of application:
  - Higher loads / extension arm lengths by using the CS-3000 in the horizontal
  - For connection of flat enclosures with narrow components and tubes in the vertical

## Panel coupling

- For connection at the rear of displays / monitors with VESA
- For connection of flat control enclosures via the rear panel
- VESA flange size, hole pattern 75 and 100
- Suspension system attachment in vertical and horizontal version possible
- Individual colour combination of all components in accordance with RAL colours



## Assembly

- Short assembly times and therefore extensive cost savings:
  - Slide the tube onto the component
  - Slightly press down
  - Tighten screws
- Cable and installation openings at all joints in the system
- Use of a DVI connector is possible







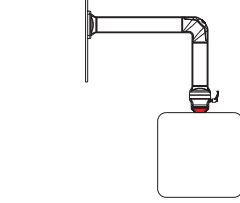
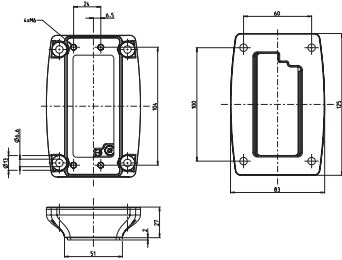

## Tubes

- Standard lengths of 250 mm up to 1500 mm in 250 mm steps

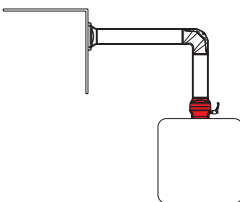
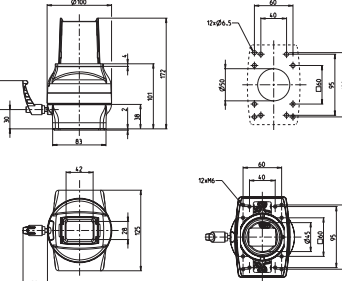
## Function

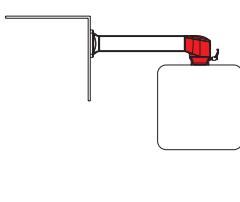
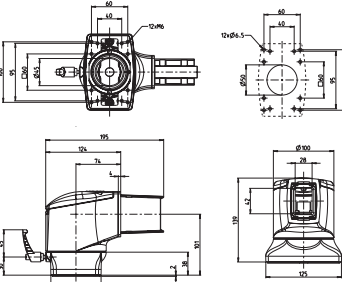
- Turning range of the rotary components: 300°
- Regulation of the rotation angle via swivel angle limiter

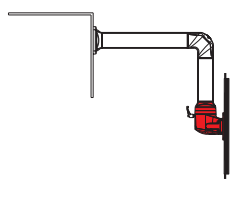
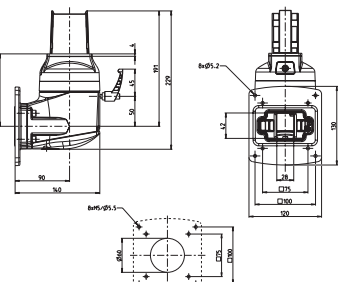

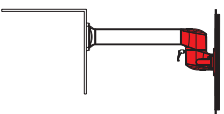
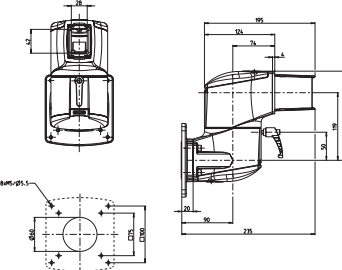



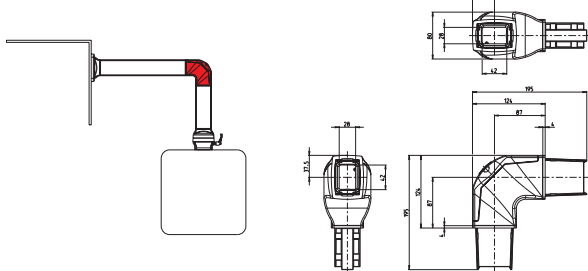

# Ordering information

	Article	Application example	Dimensions in mm
	<p><b>Adapter (narrow section)</b></p> <p><b>1017300001</b> RAL 9006 white aluminium  <b>1017300016</b> RAL 7016 anthracite grey</p> <ul style="list-style-type: none"> <li>● Only to be used together with couplings</li> <li>● For attachment to narrow BERNSTEIN enclosure sections with depths &lt; 120 mm</li> </ul>		
	<p><b>Straight coupling</b></p> <p><b>1017300002</b> RAL 9006 white aluminium  <b>1017300017</b> RAL 7016 anthracite grey</p> <ul style="list-style-type: none"> <li>● Angle of rotation 300° with stop</li> <li>(Adapter (narrow section) is required for attachment to sections &lt; 120 mm)</li> </ul>		
	<p><b>Elbow coupling</b></p> <p><b>1017300003</b> RAL 9006 white aluminium  <b>1017300018</b> RAL 7016 anthracite grey</p> <ul style="list-style-type: none"> <li>● Angle of rotation 300° with stop</li> <li>● Screw-fit installation opening</li> </ul>		
	<p><b>Panel coupling S</b></p> <p><b>1017300004</b> RAL 9006 white aluminium  <b>1017300019</b> RAL 7016 anthracite grey</p> <ul style="list-style-type: none"> <li>● For attachments to the rear of panels / displays or control enclosures with screw-fit rear panel</li> <li>● Standard hole pattern VESA 75/100</li> <li>● Angle of rotation 300° with stop</li> <li>● Screw-fit installation opening</li> </ul>		
	<p><b>Panel coupling W</b></p> <p><b>1017300005</b> RAL 9006 white aluminium  <b>1017300020</b> RAL 7016 anthracite grey</p> <ul style="list-style-type: none"> <li>● For attachments to the rear of panels / displays or control enclosures with screw-fit rear panel</li> <li>● Standard hole pattern VESA 75/100</li> <li>● Angle of rotation 300° with stop</li> <li>● Screw-fit installation opening</li> </ul>		

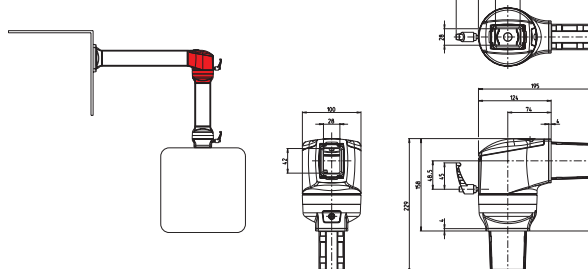

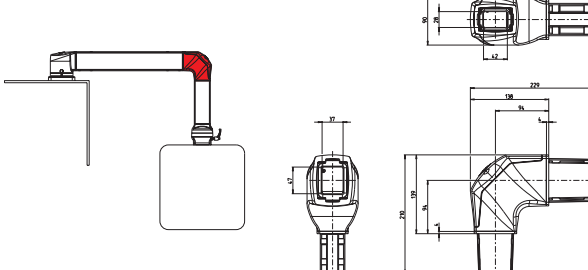

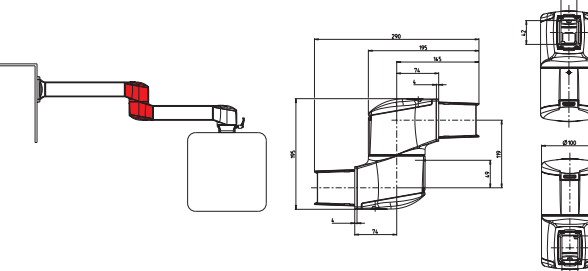

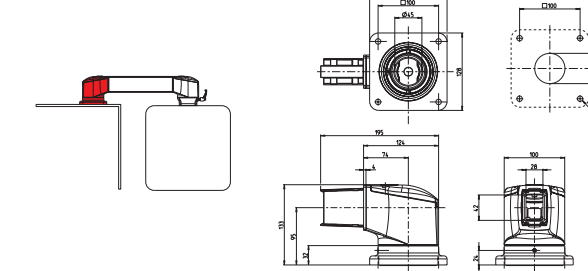

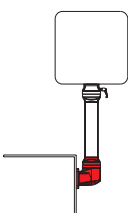
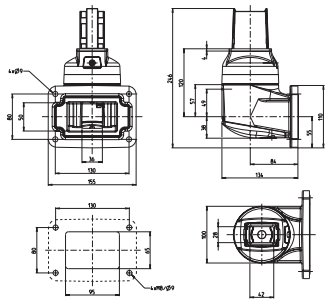

# Ordering information

CAD files available  
at [www.bernstein.eu](http://www.bernstein.eu)

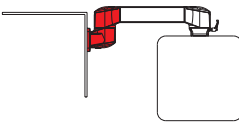
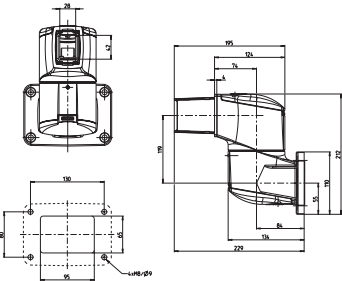
Article	Application example	Dimensions in mm
	<p><b>Elbow</b></p> <p><b>1017300007</b> RAL 9006 white aluminium <b>1017300022</b> RAL 7016 anthracite grey</p> <ul style="list-style-type: none"> <li>● Screw-fit installation opening</li> </ul>	
	<p><b>Elbow, rotary</b></p> <p><b>1017300008</b> RAL 9006 white aluminium <b>1017300023</b> RAL 7016 anthracite grey</p> <ul style="list-style-type: none"> <li>● Angle of rotation 300° with stop</li> <li>● Screw-fit installation opening</li> </ul>	
	<p><b>Reducing elbow</b></p> <p><b>1017300009</b> RAL 9006 white aluminium <b>1017300024</b> RAL 7016 anthracite grey</p> <ul style="list-style-type: none"> <li>● Elbow coupling for combination of CS-3000 neXt and CS-3000 suspension systems</li> <li>● Screw-fit installation opening</li> </ul>	
	<p><b>Intermediate joint</b></p> <p><b>1017300010</b> RAL 9006 white aluminium <b>1017300025</b> RAL 7016 anthracite grey</p> <ul style="list-style-type: none"> <li>● Angle of rotation 300° with stop</li> <li>● 2 screw-fit installation openings</li> </ul>	
	<p><b>Top joint</b></p> <p><b>1017300014</b> RAL 9006 white aluminium <b>1017300029</b> RAL 7016 anthracite grey</p> <ul style="list-style-type: none"> <li>● Angle of rotation 300° with stop</li> <li>● Screw-fit installation opening</li> </ul>	

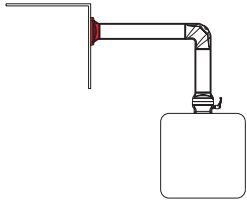
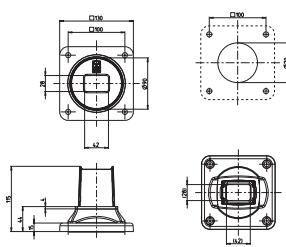
# Ordering information

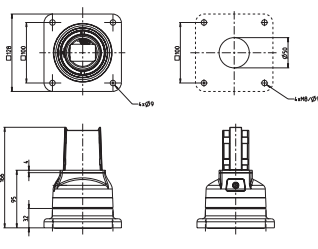
CAD files available  
at [www.bernstein.eu](http://www.bernstein.eu)

	Article	Application example	Dimensions in mm
	<p><b>Wall joint S</b></p> <p><b>1017300011</b> RAL 9006 white aluminium <b>1017300026</b> RAL 7016 anthracite grey</p> <ul style="list-style-type: none"> <li>● Angle of rotation 300° with stop</li> <li>● Screw-fit installation opening</li> </ul>		
	<p><b>Wall joint W</b></p> <p><b>1017300012</b> RAL 9006 white aluminium <b>1017300027</b> RAL 7016 anthracite grey</p> <ul style="list-style-type: none"> <li>● Angle of rotation 300° with stop</li> <li>● 2 screw-fit installation openings</li> </ul>		
	<p><b>Base / wall flange</b></p> <p><b>1017300015</b> RAL 9006 white aluminium <b>1017300030</b> RAL 7016 anthracite grey</p>		
	<p><b>Base, rotary</b></p> <p><b>1017300013</b> RAL 9006 white aluminium <b>1017300028</b> RAL 7016 anthracite grey</p> <ul style="list-style-type: none"> <li>● Angle of rotation 300° with stop</li> </ul>		
	<p><b>Tube profiles</b></p>	<p>see page 19</p>	

# Aluminium Suspension System CS-3000



## Materials

- Anodised aluminium profiles
- Components: Aluminium die cast
- Component cover plates: Polyamide
- Bearings: POM
- Seals: Neoprene







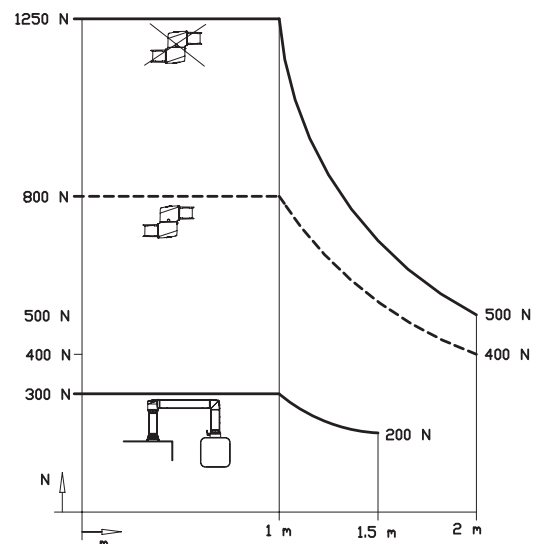

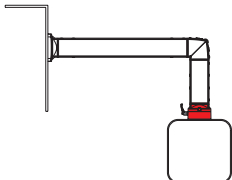
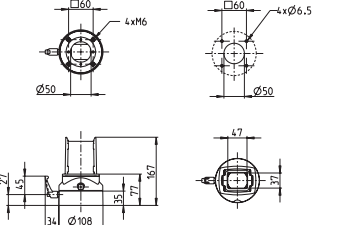

## Colour

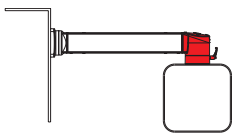
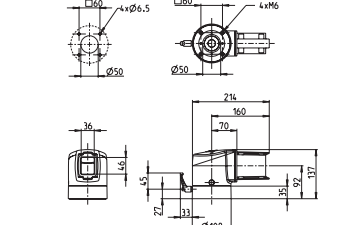
- Components: white aluminium, RAL 9006
- Connecting tubes: silver (natural) anodised

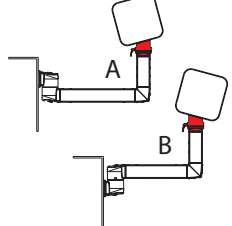
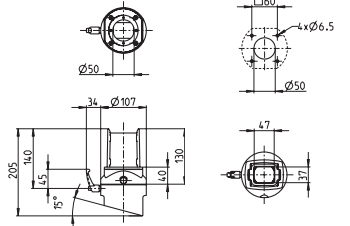
## Load diagram for static load capacity CS-3000

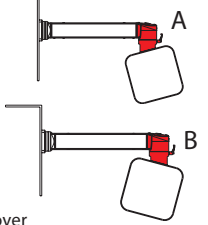
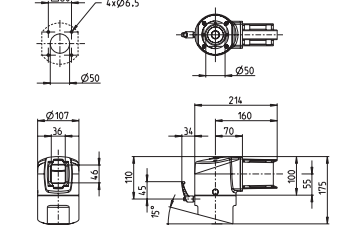

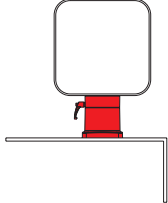
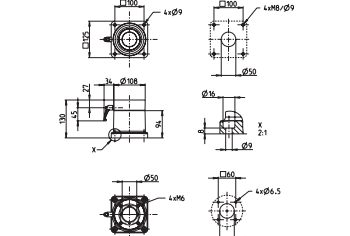

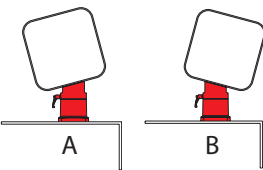
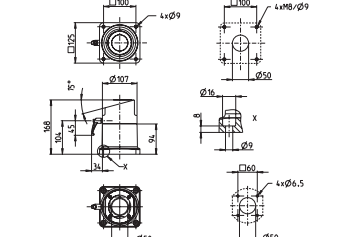





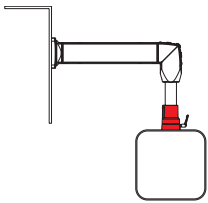
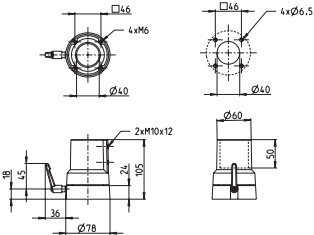

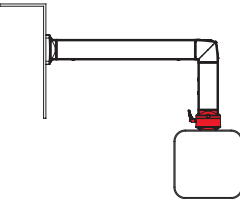
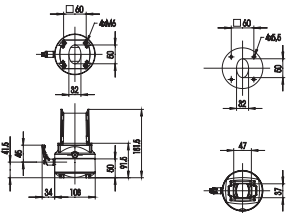
# Ordering information

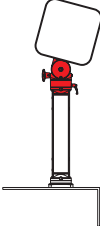
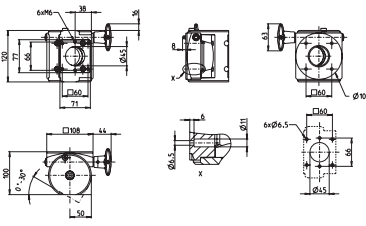

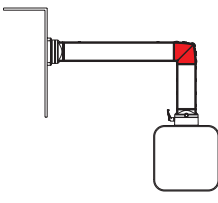
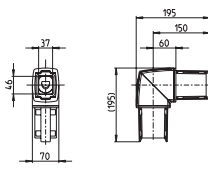

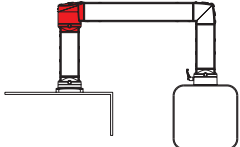
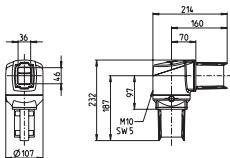

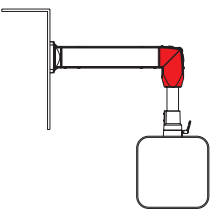
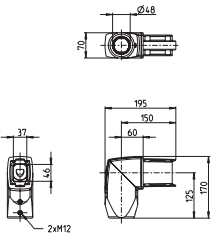

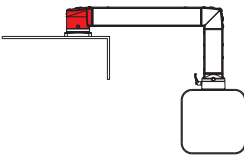
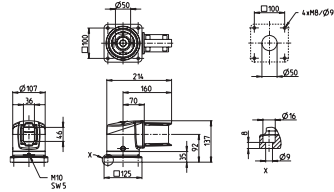

	Article	Application example	Dimensions in mm
	<p><b>Straight coupling</b></p> <p><b>1015300177</b> RAL 9006 white aluminium  <b>1015300001</b> RAL 7016 anthracite grey</p> <ul style="list-style-type: none"> <li>● Angle of rotation 300° with stop            (Adapter <b>1015300011</b> is required for attachment to sections &lt; 120 mm)</li> </ul>		
	<p><b>Elbow coupling</b></p> <p><b>1015300178</b> RAL 9006 white aluminium  <b>1015300002</b> RAL 7016 anthracite grey</p> <ul style="list-style-type: none"> <li>● Angle of rotation 300° with stop</li> <li>● Installation opening including screw-fit plastic cover</li> </ul>		
	<p><b>Tilt coupling 15° A/B</b></p> <p><b>1015300179</b> A RAL 9006 white aluminium  <b>1015300013</b> A RAL 7016 anthracite grey  <b>1015300180</b> B RAL 9006 white aluminium  <b>1015300014</b> B RAL 7016 anthracite grey</p> <ul style="list-style-type: none"> <li>● Angle of rotation 300° with stop</li> <li>● Fixed tilt of 15° (variant A tilted back – variant B tilted forward)</li> </ul>		
	<p><b>Tilt elbow coupling 15° A/B</b></p> <p><b>1015300181</b> A RAL 9006 white aluminium  <b>1015300015</b> A RAL 7016 anthracite grey  <b>1015300182</b> B RAL 9006 white aluminium  <b>1015300016</b> B RAL 7016 anthracite grey</p> <ul style="list-style-type: none"> <li>● Angle of rotation 300° with stop</li> <li>● Fixed tilt of 15° (variant A tilted back – variant B tilted forward)</li> <li>● Installation opening including screw-fit plastic cover</li> </ul>		
	<p><b>Base coupling</b></p> <p><b>1015300183</b> RAL 9006 white aluminium  <b>1015300017</b> RAL 7016 anthracite grey</p> <ul style="list-style-type: none"> <li>● Angle of rotation 300° with stop</li> </ul>		
	<p><b>Tilt base coupling 15° A/B</b></p> <p><b>1015300184</b> A RAL 9006 white aluminium  <b>1015300018</b> A RAL 7016 anthracite grey  <b>1015300185</b> B RAL 9006 white aluminium  <b>1015300019</b> B RAL 7016 anthracite grey</p> <ul style="list-style-type: none"> <li>● Angle of rotation 300° with stop</li> <li>● Fixed tilt of 15° (variant A tilted back – variant B tilted forward)</li> </ul>		

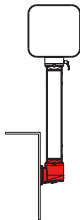
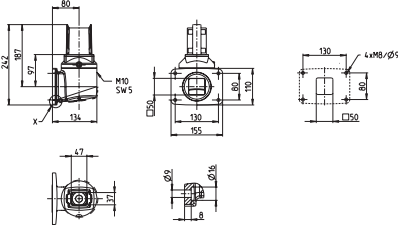
# Ordering information

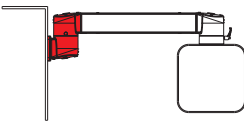
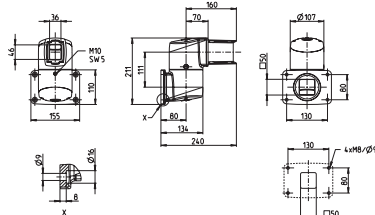
CAD files available  
at [www.bernstein.eu](http://www.bernstein.eu)

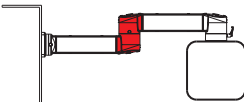
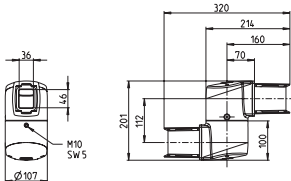

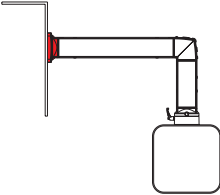
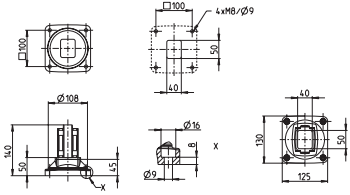

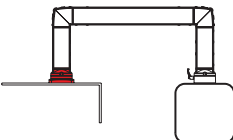
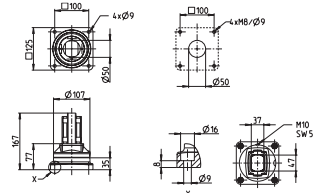



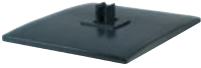
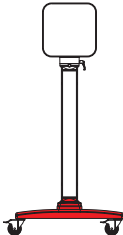
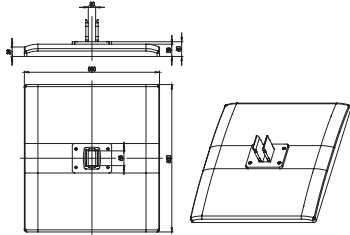

	Article	Application example	Dimensions in mm
	<p><b>Straight coupling 48</b>  <b>1013056000</b> RAL 9006 white aluminium  <b>1013050000</b> RAL 7016 anthracite grey</p> <ul style="list-style-type: none"> <li>● Angle of rotation 300° with stop</li> <li>● Only compatible with 48 mm round tube</li> </ul> <p>(Adapter <b>9806520000</b> is required for attachment to 80 mm section)</p>		
	<p><b>Coupling for Siemens SIMATIC Pro®</b>  <b>1015300187</b> RAL 9006 white aluminium  <b>1015300043</b> RAL 7016 anthracite grey</p> <ul style="list-style-type: none"> <li>● Customised coupling for Siemens SIMATIC Pro®</li> <li>● Angle of rotation 300° with stop</li> <li>● Other coupling combination are available upon request</li> </ul>		
	<p><b>Tilt adapter (30° infinitely variable)</b>  <b>1015300193</b> RAL 9006 white aluminium  <b>1015300012</b> RAL 7016 anthracite grey</p> <ul style="list-style-type: none"> <li>● Infinitely variable tilt up to 30°</li> <li>● Maximum load: 300 N</li> <li>● <b>Not compatible with 1013050000</b>, as well as Siemens SIMATIC Pro® couplings (Used only together with couplings)</li> </ul>		
	<p><b>Elbow</b>  <b>1015300195</b> RAL 9006 white aluminium  <b>1015300008</b> RAL 7016 anthracite grey</p> <ul style="list-style-type: none"> <li>● With installation opening including screw-fit plastic cover</li> </ul>		
	<p><b>Elbow, rotary</b>  <b>1015300196</b> RAL 9006 white aluminium  <b>1015300009</b> RAL 7016 anthracite grey</p> <ul style="list-style-type: none"> <li>● Angle of rotation 300° with stop</li> <li>● Installation opening including screw-fit plastic cover</li> </ul>		
	<p><b>Elbow, reduced RD 48</b>  <b>1015300197</b> RAL 9006 white aluminium  <b>1015300020</b> RAL 7016 anthracite grey</p> <ul style="list-style-type: none"> <li>● Reducer elbow from the square tube to 48 mm round tube</li> </ul>		

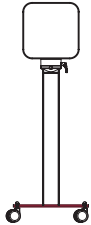
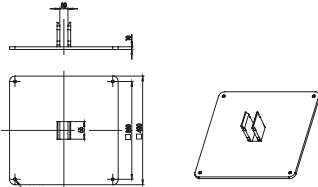
# Ordering information

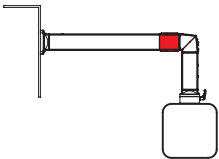
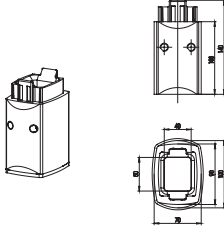
	Article	Application example	Dimensions in mm
	<p><b>Top joint</b></p> <p><b>1015300198</b> RAL 9006 white aluminium  <b>1015300003</b> RAL 7016 anthracite grey</p> <ul style="list-style-type: none"> <li>● Angle of rotation 300° with stop</li> <li>● Installation opening including screw-fit plastic cover</li> </ul>		
	<p><b>Wall joint S</b></p> <p><b>1015300199</b> RAL 9006 white aluminium  <b>1015300006</b> RAL 7016 anthracite grey</p> <ul style="list-style-type: none"> <li>● Angle of rotation 300° with stop</li> <li>● Installation opening including screw-fit plastic cover</li> </ul>		
	<p><b>Wall joint W</b></p> <p><b>1015300200</b> RAL 9006 white aluminium  <b>1015300007</b> RAL 7016 anthracite grey</p> <ul style="list-style-type: none"> <li>● Angle of rotation 300° with stop</li> <li>● 2 installation openings including screw-fit plastic covers</li> </ul>		
	<p><b>Intermediate joint</b></p> <p><b>1015300201</b> RAL 9006 white aluminium  <b>1015300004</b> RAL 7016 anthracite grey</p> <ul style="list-style-type: none"> <li>● Angle of rotation 300° with stop</li> <li>● 2 installation openings including screw-fit plastic covers</li> </ul>		
	<p><b>Base / wall flange</b></p> <p><b>1015300204</b> RAL 9006 white aluminium  <b>1015300010</b> RAL 7016 anthracite grey</p>		
	<p><b>Base, rotary</b></p> <p><b>1015300205</b> RAL 9006 white aluminium  <b>1015300005</b> RAL 7016 anthracite grey</p> <ul style="list-style-type: none"> <li>● Angle of rotation 300° with stop</li> </ul>		

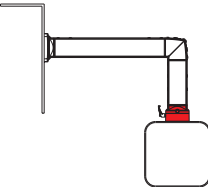
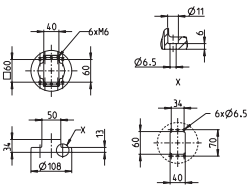
# Ordering information

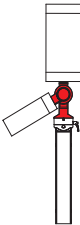
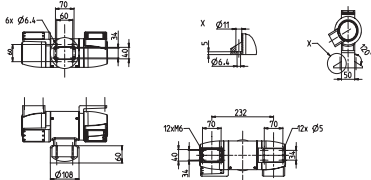
CAD files available  
at [www.bernstein.eu](http://www.bernstein.eu)

	Article	Application example	Dimensions in mm
	<p><b>Large free-standing base</b>  <b>1015300206</b> RAL 9006 white aluminium  <b>1015300027</b> RAL 7016 anthracite grey</p>		
	<p><b>Small free-standing base</b>  <b>1015300207</b> RAL 9006 white aluminium  <b>1015300028</b> RAL 7016 anthracite grey</p>		
	<p><b>Tube adapter</b>  <b>1015300208</b> RAL 9006 white aluminium  <b>1015300039</b> RAL 7016 anthracite grey</p> <ul style="list-style-type: none"> <li>Required for connecting tubes shortened directly at place of installation</li> </ul> <p>(Tubes machined at one end and of unspecified lengths can be cut to size and connected to the system with the tube adapter)</p>		
	<p><b>Adapter (narrow section)</b>  <b>1015300209</b> RAL 9006 white aluminium  <b>1015300011</b> RAL 7016 anthracite grey</p> <ul style="list-style-type: none"> <li>For attachment to BERNSTEIN enclosures with depths &lt;120 mm</li> </ul> <p>(Only to be used together with couplings)</p>		
	<p><b>Coupling head</b>  <b>9808017400</b> RAL 9006 white aluminium  <b>9806818000</b> RAL 7016 anthracite grey</p> <ul style="list-style-type: none"> <li>Coupling head for infinitely variable, pivoted attachment of control enclosures (infinitely variable from 0° to 30°) and keyboard consoles (infinitely variable from 0° to 20°) to coupling components CS-3000</li> </ul>		
	<p><b>Bent Tube</b>  <b>Customer-specific</b></p> <ul style="list-style-type: none"> <li>Bent tube manufactured to individual specifications (dimensions min. 500 mm, max. 1000 mm)</li> </ul>	<p>see page 18</p>	

# Vertically adjustable module CS-3000 HV

The vertically adjustable suspension system CS-3000 HV allows users of all sizes to work in an ergonomic manner. The gas-filled damper system supports the user while the height is being raised or lowered and prevents it from dropping suddenly after the clamping lever is released. A high level of operating convenience and ease of installation is guaranteed by the interior cable ducting.



Art. No. 101.5300.022	CS-3000 HV 1000/100
Art. No. 101.5300.023	CS-3000 HV 800/100
Art. No. 101.5300.029	CS-3000 HV 1000/150
Art. No. 101.5300.030	CS-3000 HV 800/150
Art. No. 101.5300.031	CS-3000 HV 1000/200
Art. No. 101.5300.032	CS-3000 HV 800/200
Art. No. 101.5300.033	CS-3000 HV 1000/300
Art. No. 101.5300.034	CS-3000 HV 800/300

Explanation: Designation **CS-3000 HV800/100**

Vertically adjustable system

Length of square tube

Force of gas pressure spring  
in Newtons [N]

Coupling 48, stand base or mounting bracket and enclosure are not included in the scope of delivery.

## Selection parameters

- The selection of the size of the gas pressure spring depends on the total weight and the ambient temperature

- The total weight is calculated from:  
Enclosure + installed equipment +  
coupling components

Ambient temperature	40 °C	100 N (6 – 11 kg)	150 N (11 – 19 kg)	200 N (19 – 29 kg)	300 N (29 – 39 kg)
	30 °C	100 N (5,5 – 10,5 kg)	150 N (10,5 – 18 kg)	200 N (18 – 27,5 kg)	300 N (27,5 – 37 kg)
	20 °C	100 N (5 – 10 kg)	150 N (10 – 17 kg)	200 N (17 – 26 kg)	300 N (26 – 35 kg)
Gas pressure spring force / total weight					



# Accessories

## Article



### Swivel angle limiter CS-3000

**9805296000**

- Swivel angle limiter for coupling and joint components
- Adjustable in steps of 13.7°
- Contains ten Ø 10 mm steel balls

## Article



### Swivel angle limiter CS-3000 neXt

**9806906000**

- Swivel angle limiter for coupling and joint components
- Adjustable in steps of 30°
- Contains 6 swivel angle limiter

### Apparatus castors

**9808015300**



- Castor set, consisting of 2 steering castors and 2 steering castors with total locking for free-standing bases
- Load-bearing capacity of each castor 70 kg

### Levelling feet

**9808012900**



- Height-adjustable feet (1 set = 4 pieces) for free-standing bases

### Floor anchoring

**9808014100**



- Floor anchoring set for the large stand

### Industrial castors

**9808012800**



- Castor set, consisting of 4 steering castors with locking brake
- Load-bearing capacity of each castor 50 kg

### Signal lamp adapter

**9805317000 Joint components**  
**9805318000 Elbow components**



- For connecting commercially available 25 mm diameter signal lamps to CS-3000 suspension system components

### Adapter plate

**9806678000**



- For connecting adapter flange to coupling 48

(9806520000 required together with coupling RD 48 for attachment to CC-4000 section 80)

### Adapter flange

**9806649000**



- For enclosure with door section and / or keyboard

### Screw cover set

**9806590000**



- Plastic covers for sealing the tube fastening screws RAL 9006
- Kit contains 50 pcs.

# CS-3000 Bent Tube

Design, simple assembly and ease of cleaning as well as variety of components, load bearing capacity and quality are important criteria for the choice of a suitable suspension system. All of these characteristics are offered by BERNSTEIN's CS-3000 Family including the new Bent Tube. Unlike traditional types of configurations (tube – elbow – tube), the exceptional single piece construction offers a wide range of application opportunities. It is particularly suitable for operator control panels or console enclosures with suspension arm attachments on the bottom, as it reduces the possibility of projection impact injury to machine operator and surrounding people.

## Product features

- Material: Anodised aluminium
- Cross-sectional dimension of the tube: 70 x 90 mm (to match CS-3000 components)
- No limitation of the load bearing capacity compared to traditional systems with straight tubes
- Reduced assembly time due to its elbow free design
- Snag free cable routing
- Manufactured to individual specifications (dimensions min. 500 mm, max. 1000 mm)



## Application examples



# Tubes

	Standard lengths (available from stock)	Article number	Tube cross sections
<b>CS-3000 neXt Aluminium connection section</b>			



Length 55 x 75 x 250 mm	<b>9524700001</b>
Length 55 x 75 x 500 mm	<b>9524700002</b>
Length 55 x 75 x 750 mm	<b>9524700003</b>
Length 55 x 75 x 1000 mm	<b>9524700004</b>
Length 55 x 75 x 1250 mm	<b>9524700005</b>
Length 55 x 75 x 1500 mm	<b>9524700006</b>

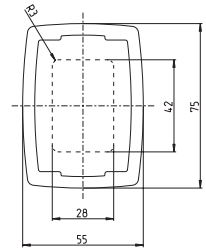

<b>CS-3000 Aluminium connection section</b>			
---	--	--	--



Length 70 x 90 x 250 mm	<b>9524500001</b>
Length 70 x 90 x 500 mm	<b>9524500002</b>
Length 70 x 90 x 750 mm	<b>9524500003</b>
Length 70 x 90 x 1000 mm	<b>9524500004</b>
Length 70 x 90 x 1250 mm	<b>9524500005</b>
Length 70 x 90 x 1500 mm	<b>9524500006</b>
Length 70 x 90 x 1750 mm	<b>9524500007</b>
Length 70 x 90 x 2000 mm	<b>9524500008</b>

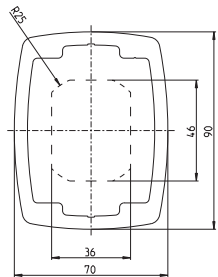

**Tubes machined at one end**  
(machining templates supplied, available from stock)

Length 70 x 90 x 1000 mm	<b>9524500009</b>
Length 70 x 90 x 2000 mm	<b>9524500010</b>

If one of our standard lengths does not suit your requirements, we can also supply tubes machined at one end. Simply shorten to the required length and use the supplied template to machine the shortened end.

**Machined tubes to required lengths**

We can also supply completely machined tubes to the length you require (price and delivery time on request). Or use our Express Service.

**Express Service**

<b>Round aluminium tubing</b>			
Round aluminium tubes in different lengths. We can also supply completely machined tubes to the length you require. (Prices and delivery time on request)			

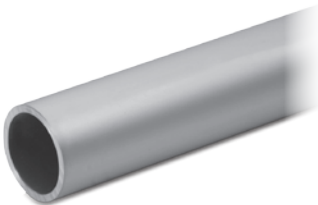

Length 48 x 4 x 250 mm	<b>9521400000</b>
Length 48 x 4 x 500 mm	<b>9521401000</b>
Length 48 x 4 x 750 mm	<b>9521402000</b>
Length 48 x 4 x 1000 mm	<b>9521403000</b>

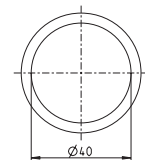



**Switch systems –  
Economy meets safety**



**Sensor systems –  
Compact intelligence**



**Enclosure systems –  
Function and design**

[www.bernstein.eu](http://www.bernstein.eu)

## Contact

**International Headquarters  
BERNSTEIN AG**  
Hans-Bernstein-Str. 1  
32457 Porta Westfalica  
Fon +49 571 793-0  
Fax +49 571 793-555  
[info@de.bernstein.eu](mailto:info@de.bernstein.eu)  
[www.bernstein.eu](http://www.bernstein.eu)

**Denmark  
BERNSTEIN A/S**  
Fon +45 7020 0522  
Fax +45 7020 0177  
[info@dk.bernstein.eu](mailto:info@dk.bernstein.eu)

**France  
BERNSTEIN S.A.R.L.**  
Fon +33 1 64 66 32 50  
Fax +33 1 64 66 10 02  
[info@fr.bernstein.eu](mailto:info@fr.bernstein.eu)

**Italy  
BERNSTEIN S.r.l.**  
Fon +39 035 4549037  
Fax +39 035 4549647  
[info@it.bernstein.eu](mailto:info@it.bernstein.eu)

**United Kingdom  
BERNSTEIN Ltd**  
Fon +44 1922 744999  
Fax +44 1922 457555  
[info@uk.bernstein.eu](mailto:info@uk.bernstein.eu)

**Austria  
BERNSTEIN GmbH**  
Fon +43 2256 62070-0  
Fax +43 2256 62618  
[info@at.bernstein.eu](mailto:info@at.bernstein.eu)

**Switzerland  
BERNSTEIN (Schweiz) AG**  
Fon +41 44 775 71-71  
Fax +41 44 775 71-72  
[info@ch.bernstein.eu](mailto:info@ch.bernstein.eu)

**Hungary  
BERNSTEIN Kft.**  
Fon +36 1 4342295  
Fax +36 1 4342299  
[info@hu.bernstein.eu](mailto:info@hu.bernstein.eu)

**China  
BERNSTEIN Safe Solutions  
(Taicang) Co., Ltd.**  
Fon +86 512 81608180  
Fax +86 512 81608181  
[info@bernstein-safesolutions.cn](mailto:info@bernstein-safesolutions.cn)